



www.continentt.com

Havaci Binbasi Mehmet Sk.
No:2/13 Bostanci/Kadikoy

Phone: +90 (216) 709 90 16
Email: info@continentt.com



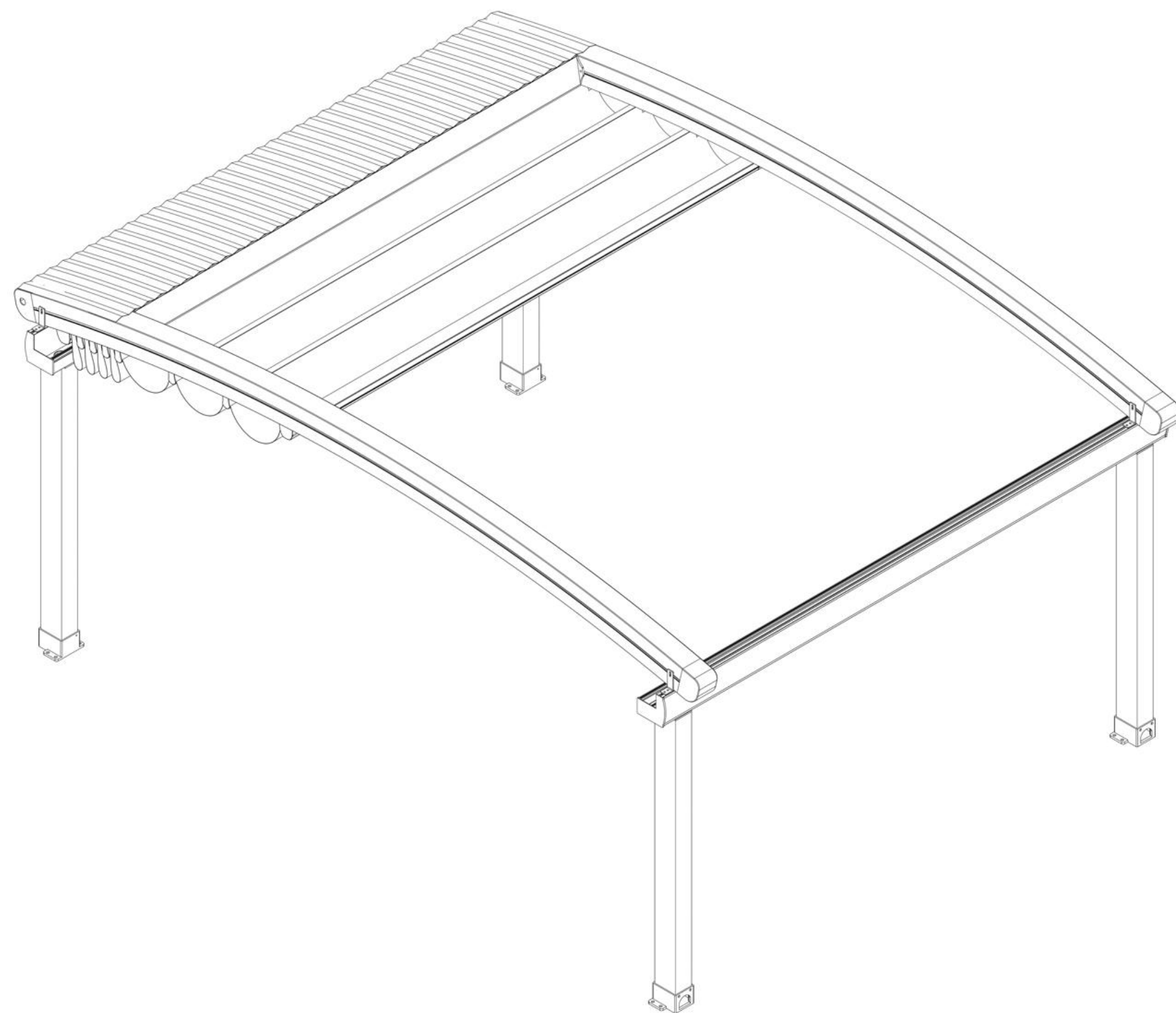

VENUS RETRACTABLE ROOF SYSTEM

Venus retractable pergola system is designed to increase the usability of open areas against rain and sunlight.

The unique side channel design of Venus rail profiles (125mm x 60mm, 80mmx135mm, 115mmx150mm, 200mm x 100mm) facilitates the installation of the system.

The system can be applied based on a maximum width of 13 meters and a forward opening of 14 meters according to the space requirements.

The system provides the opportunity to be used in an area of 182 square meters with a single button with the remote control method.

- Easy on-off function via direct drive motor system,
- Remote control for system and lighting,
- Heat resistant and waterproof blackout fabric of German origin, offered with alternative color options,
- Production with electrostatic powder painting technique,
- In addition to all RAL paint options, special texture and exclusive color alternatives,
- Air and water proof patented isolation joint profile in applications involving more than one system,
- High quality extruded aluminum (6063 alloy),
- High quality stainless steel connectors (316 quality),
- Optional guillotine, sliding and folding glass applicability around the system,
- Production in CE and TUV standards.
- Stainless steel wire reinforced and high-strength timing belt is used on the rails.
- Compact 26 rpm direct drive motor box increases the movement speed of the system.
- The main front fabric profile provides proportional tension on the fabric by reducing the stretching of the intermediate fabric profiles with its strong and balanced traction power.
- Patented six-wheeled trolleys ensure that the system works flawlessly.
- Maximum waterproofing is ensured with the special wick application surrounding the system.
- The patented isolation joint profile used in the junction of the rails provides air and water tightness between two systems that are next to each other.
- Stainless steel connection apparatus and extruded aluminum profiles are highly resistant to oxidation.
- Ergonomic protection roof extends the life of the mechanism by protecting the fabric and engine parts against external factors.
- With the lighting option integrated into the system, a lighting solution is provided in large areas without the need for additional electrical installations.

- System construction is aluminum.
- System mounting options are wall-mounted or optionally integrated into the independent carrier steel construction.
- System profile section dimensions:
 - Carrier rail; 60x125mmx2mm / 80x135x2mm / 110x150x2mm / 100x200x2mm
 - Front strut ;100x130x2,5mm
 - Fabric profiles;
 - Intermediate profile 35mmx60mmx1.5mm & Main front profile 60mmx80mmx1.5mm (Standard)
 - Intermediate profile 45mmx68mmx1.8mm & Main front profile 60mmx80mmx1.8mm (HDD Lux)
 - Optional Front beam / stream profile; 155mmx160mmx3mm
 - Optional sunshade profile; 30mmx200mmx2mm
- Optional carrier steel construction dimensions are specially resolved according to the project details.
- Material; Serge Ferari brand of French origin or Sioen brand of Belgian origin, 3-layer Black-out feature and weight 800 gr/m².
 - It has the feature of not reflecting light, flameproofing and equal stretching.

- Resistant to water permeability and tearing (except for sharp-piercing external factors).
 - Color options are cream, white, gray and cappuccino.
 - Alternatively, three-dimensional or opaque fabric options are available.
- Remote control controlled motor and optional dimmer integrated lighting system is French origin Somfy brand.
- The motor values used according to the measurement details of the system:
 - Altus 60 RTS 85Nm/12Rpm -Altus 60 RTS 120Nm/12Rpm -In applications of 1000X800cm and above, system operation is strengthened by double motor automation.
- Patented 6-wheel carrier RC6 trolleys in the rail ensure stable and silent operation of the system.
- Fluent movement of the fabric is ensured by the timing tension and traction system.
- Water drainage is solved without any problems through the rain gutter integrated into the front beams.
- All fasteners, bolts and pins are made of stainless steel, increasing the strength of the system.

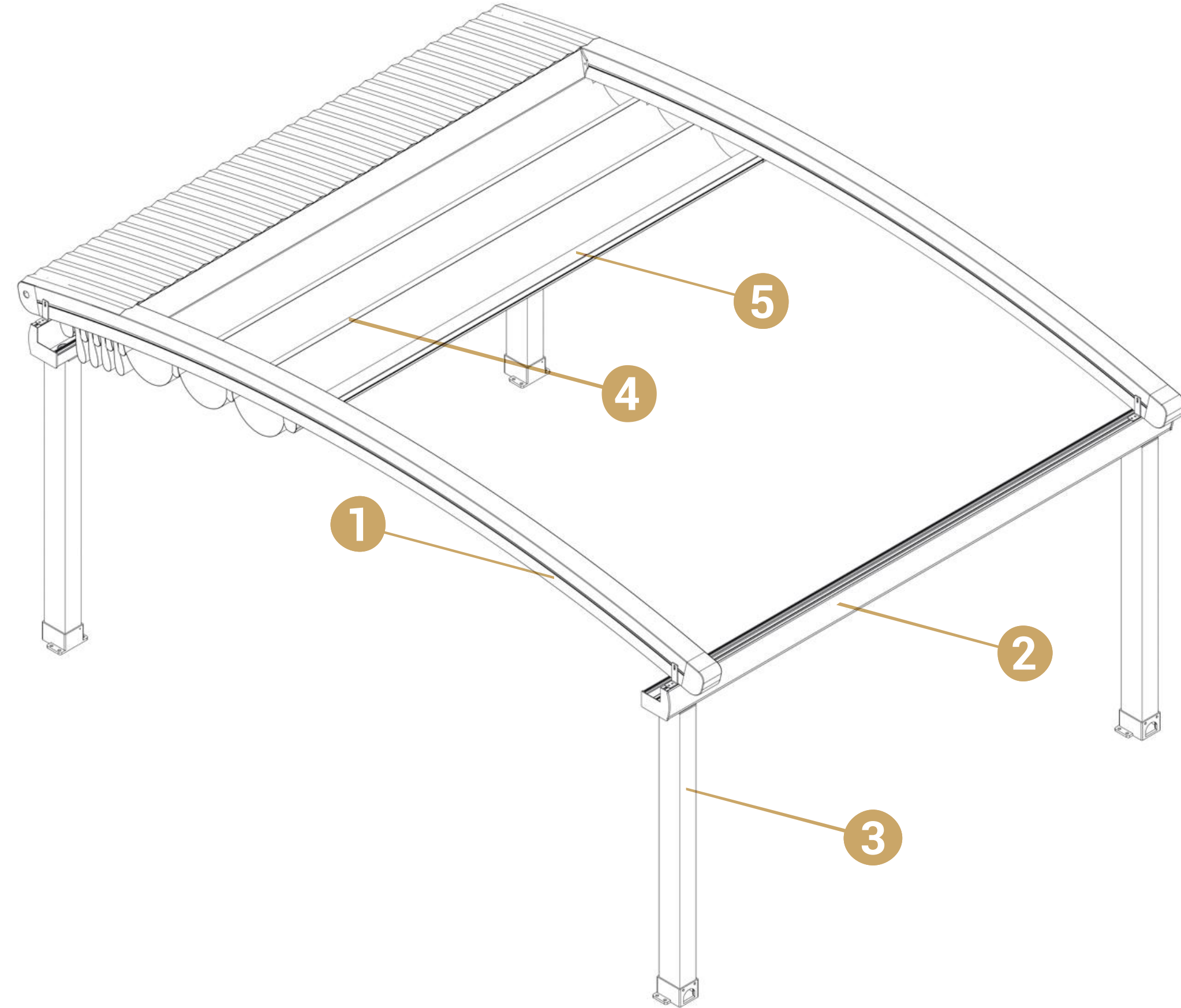

EVO series

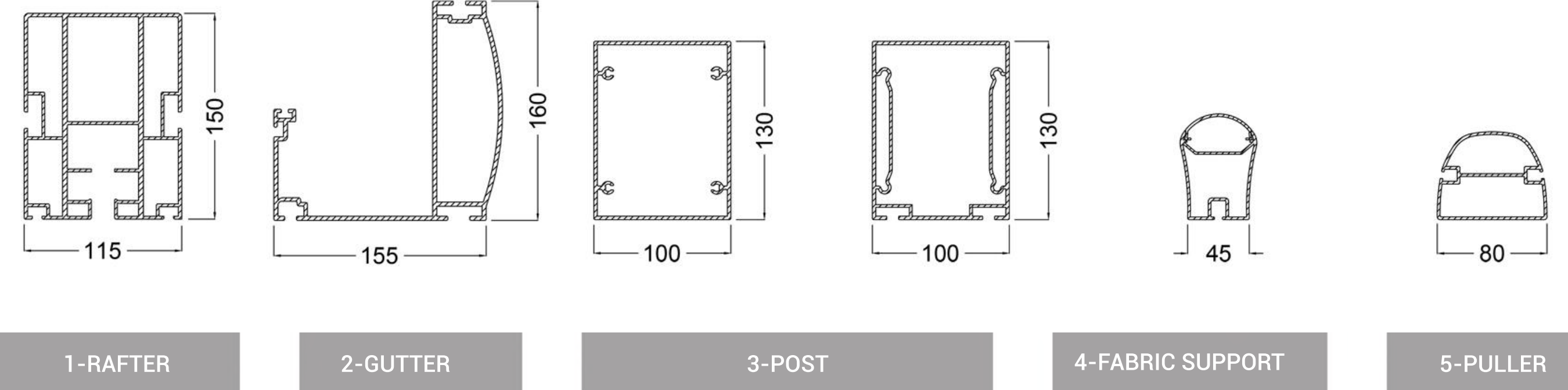

ECO series

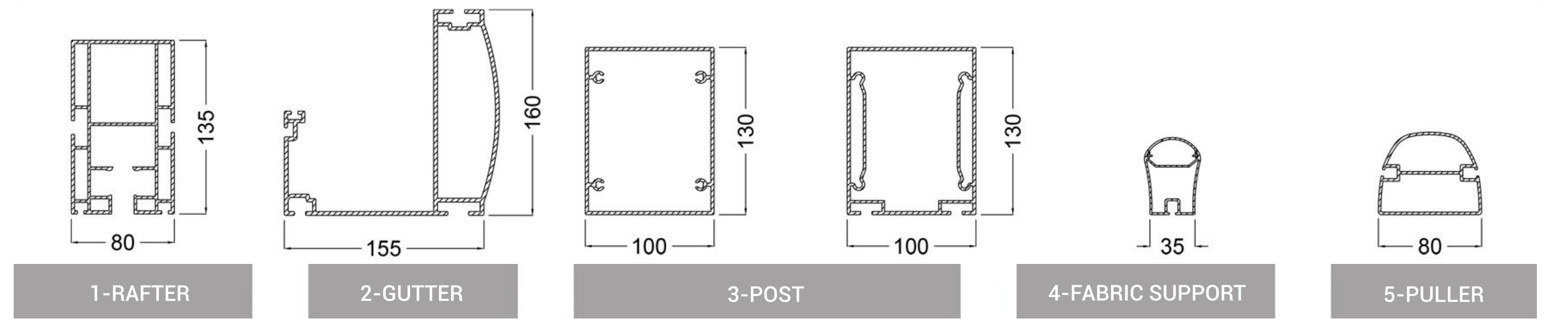

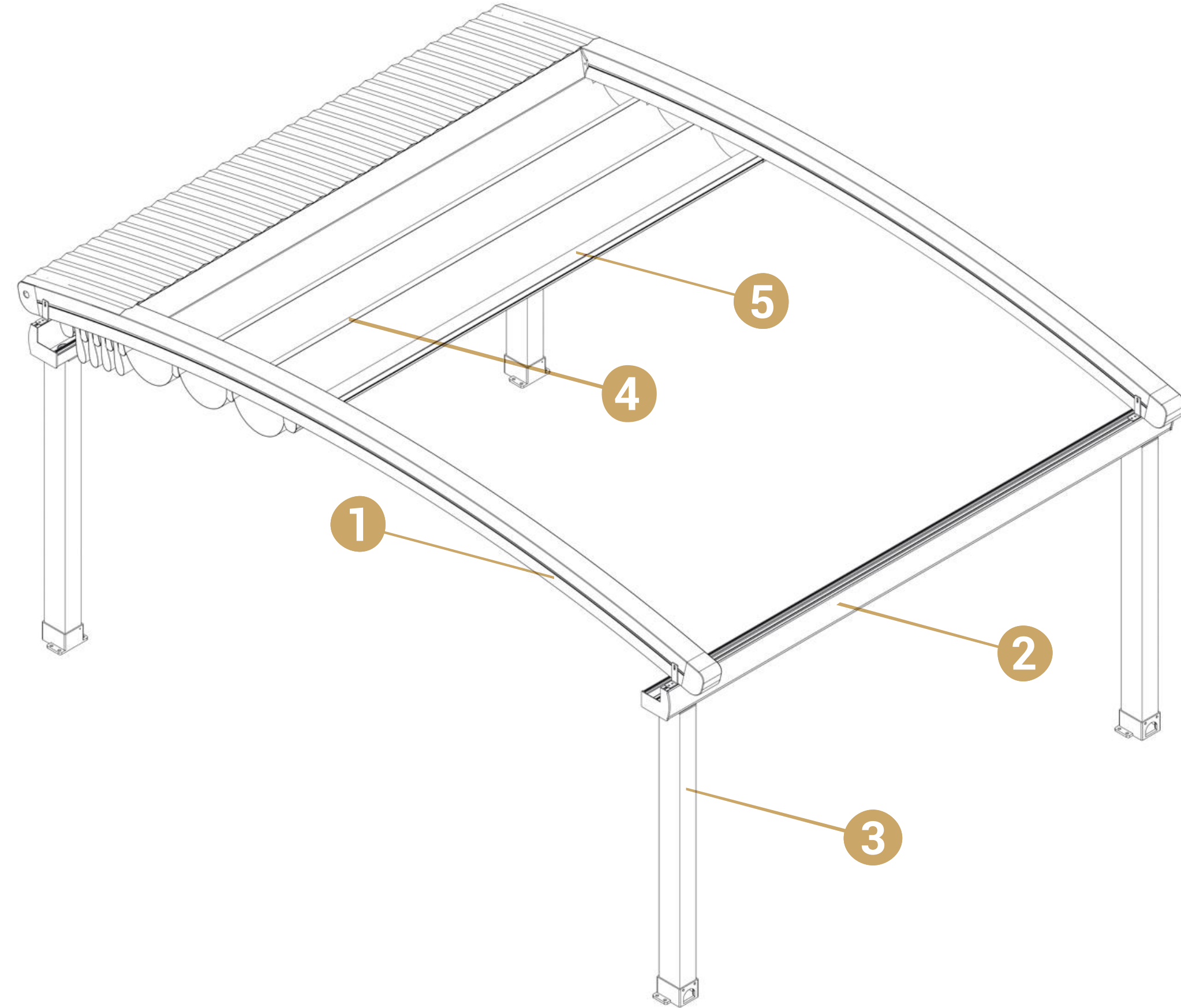

MAXI series

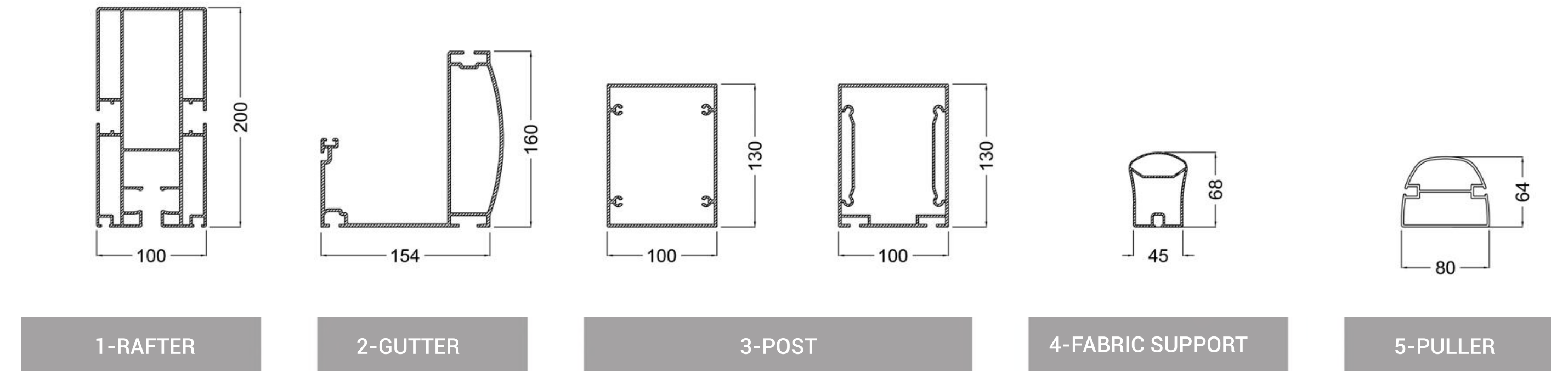

MINI series

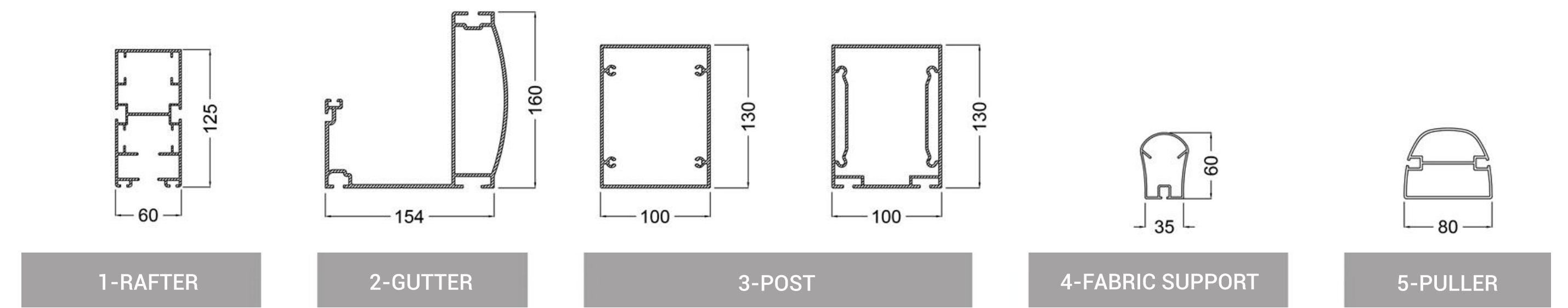

ONE MODULE

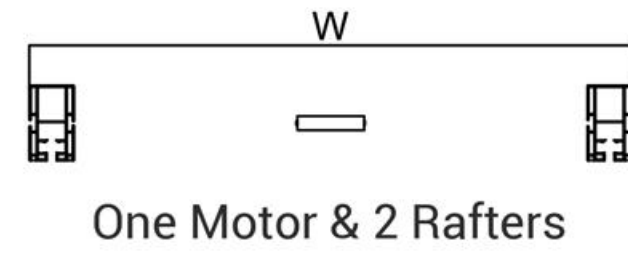

200 cm > 450 cm

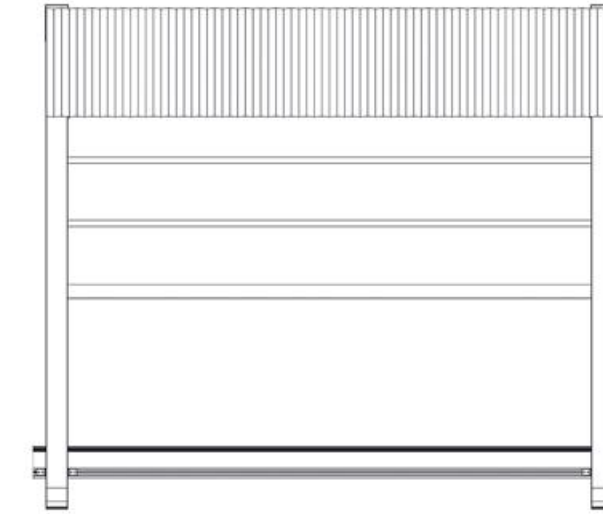

TWO MODULES

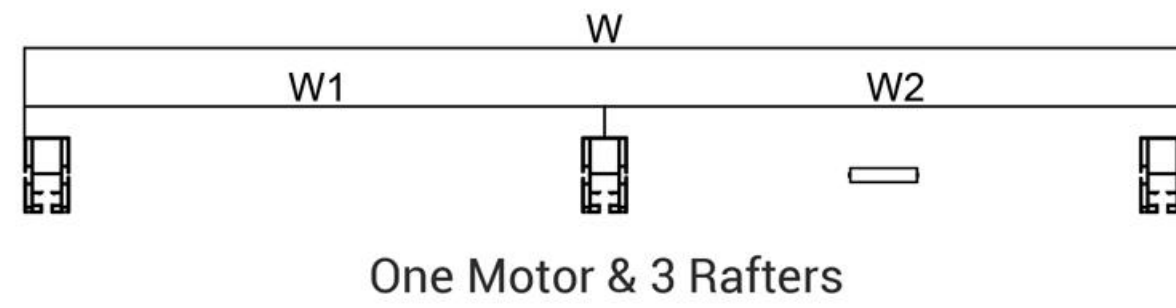

450 cm > 900 cm

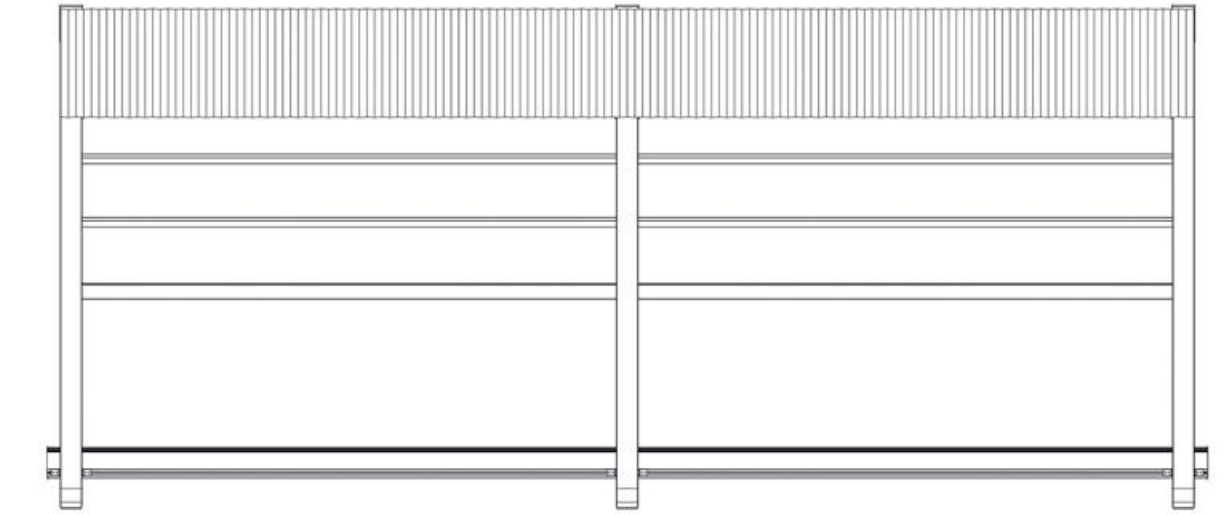

THREE MODULES

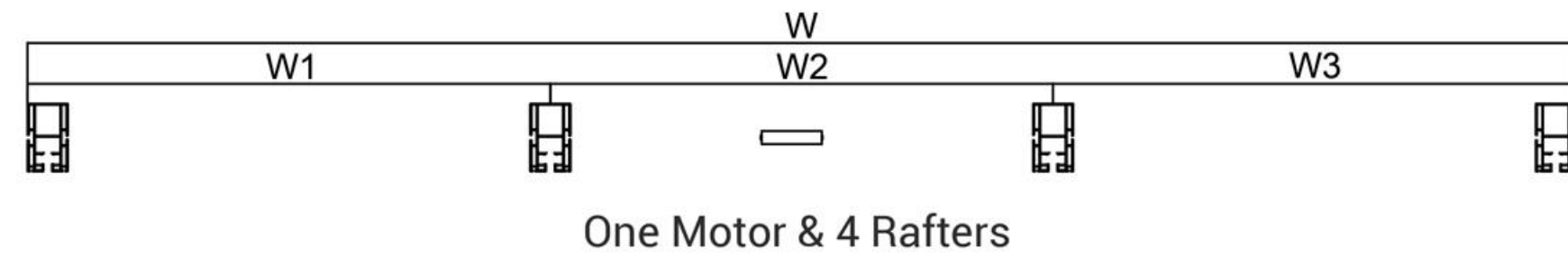

900 cm > 1300 cm

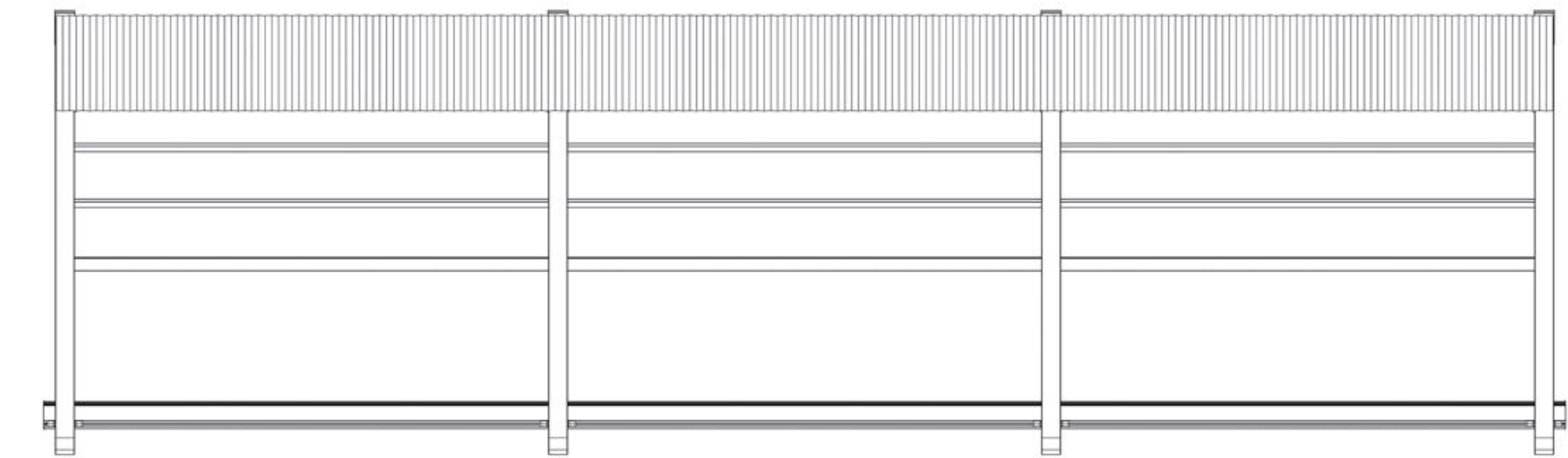

ECO series

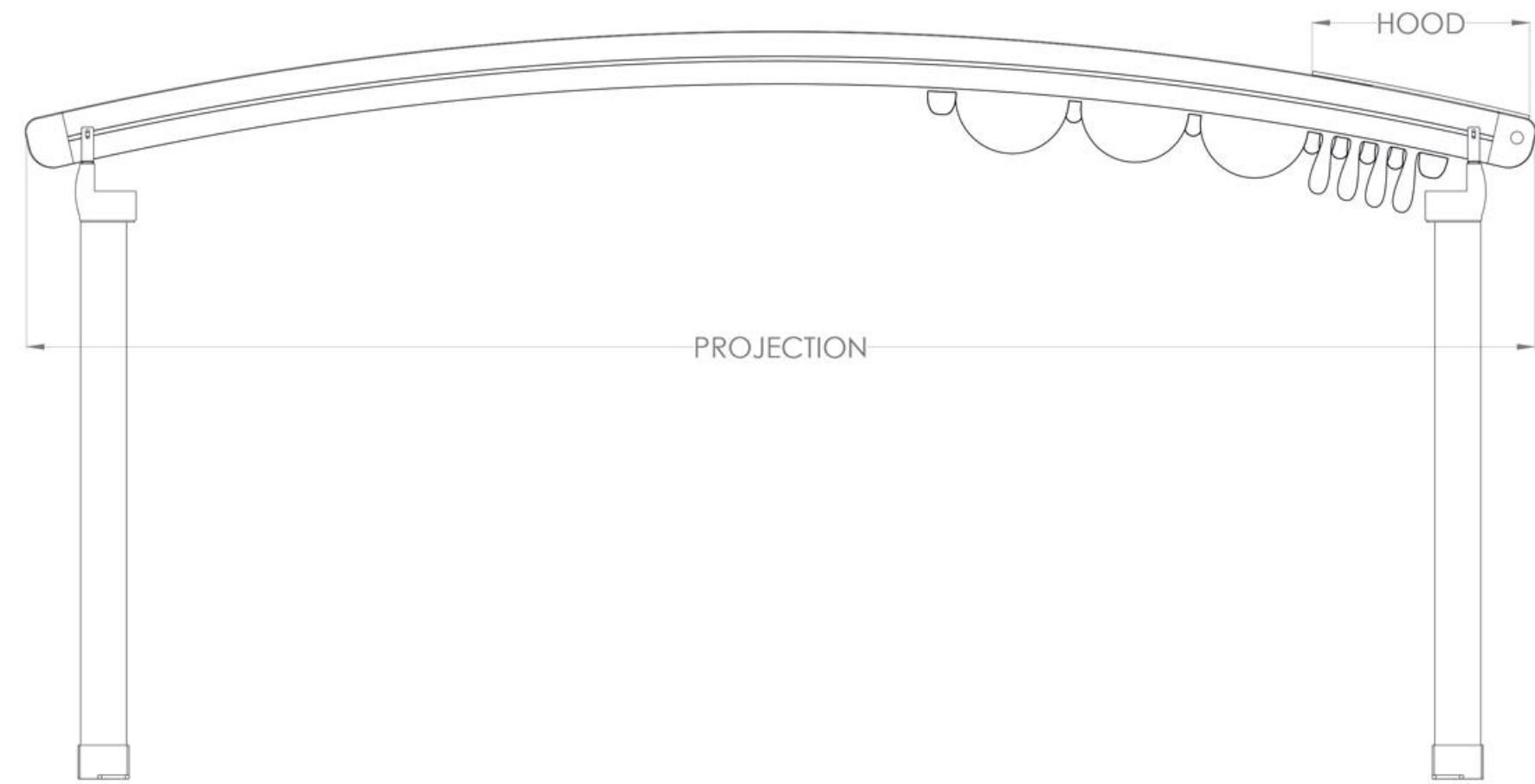

	HOOD cm	FAB. SUP. PROFILES pc
300	60.5	5
350	66	6
400	71.5	7
450	77	8
500	82.5	9
550	88	10
600	93.5	11
650	99	12
700	104.5	13

EVO series

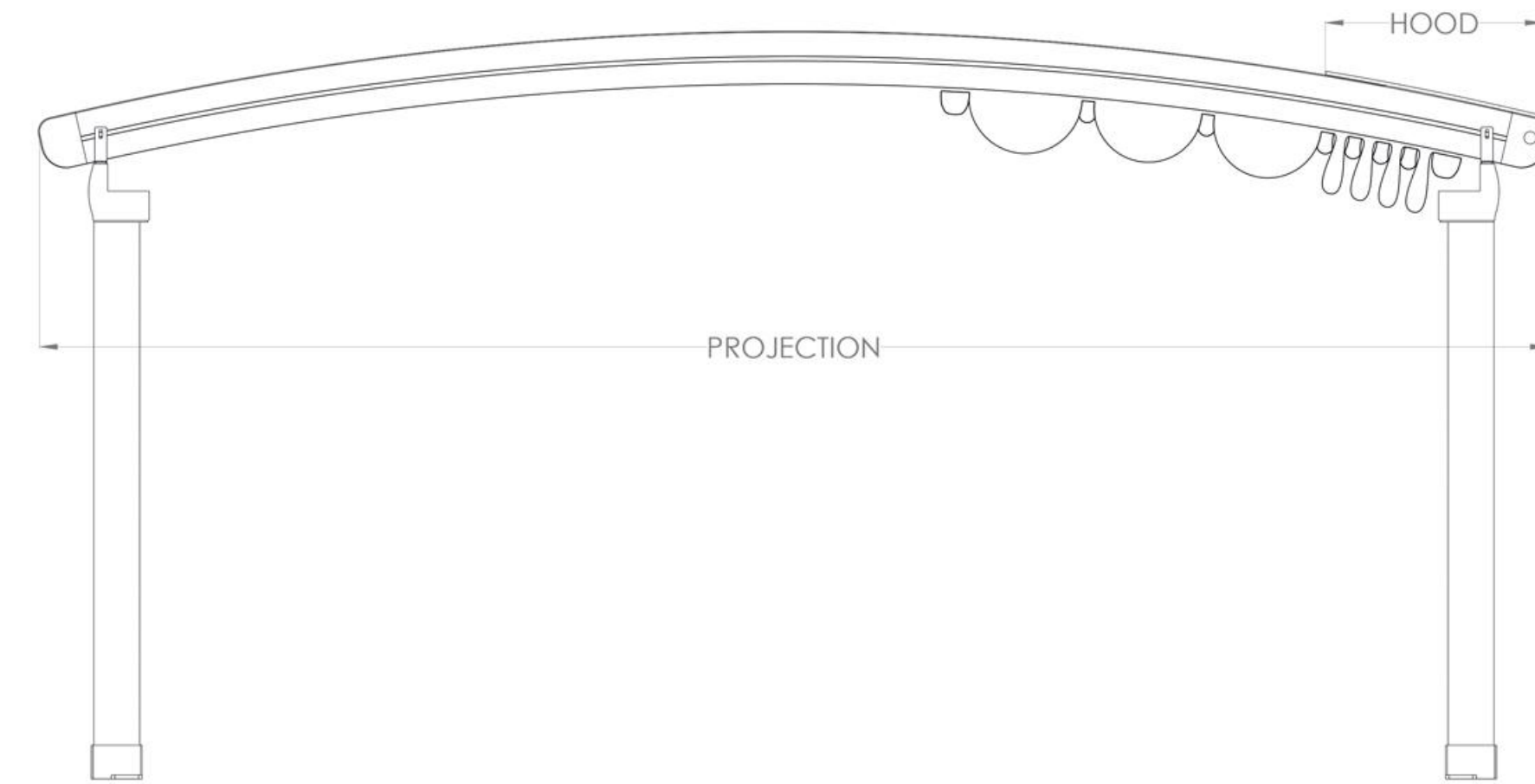

	HOOD cm	FAB. SUP. PROFILES pc
300	60.5	5
350	66	6
400	71.5	7
450	77	8
500	82.5	9
550	88	10
600	93.5	11
650	99	12
700	104.5	13
750	110	14
800	115.5	15
850	121	16
900	126.5	17
950	132	18
1000	137.5	19
1050	143	20
1100	148.5	21

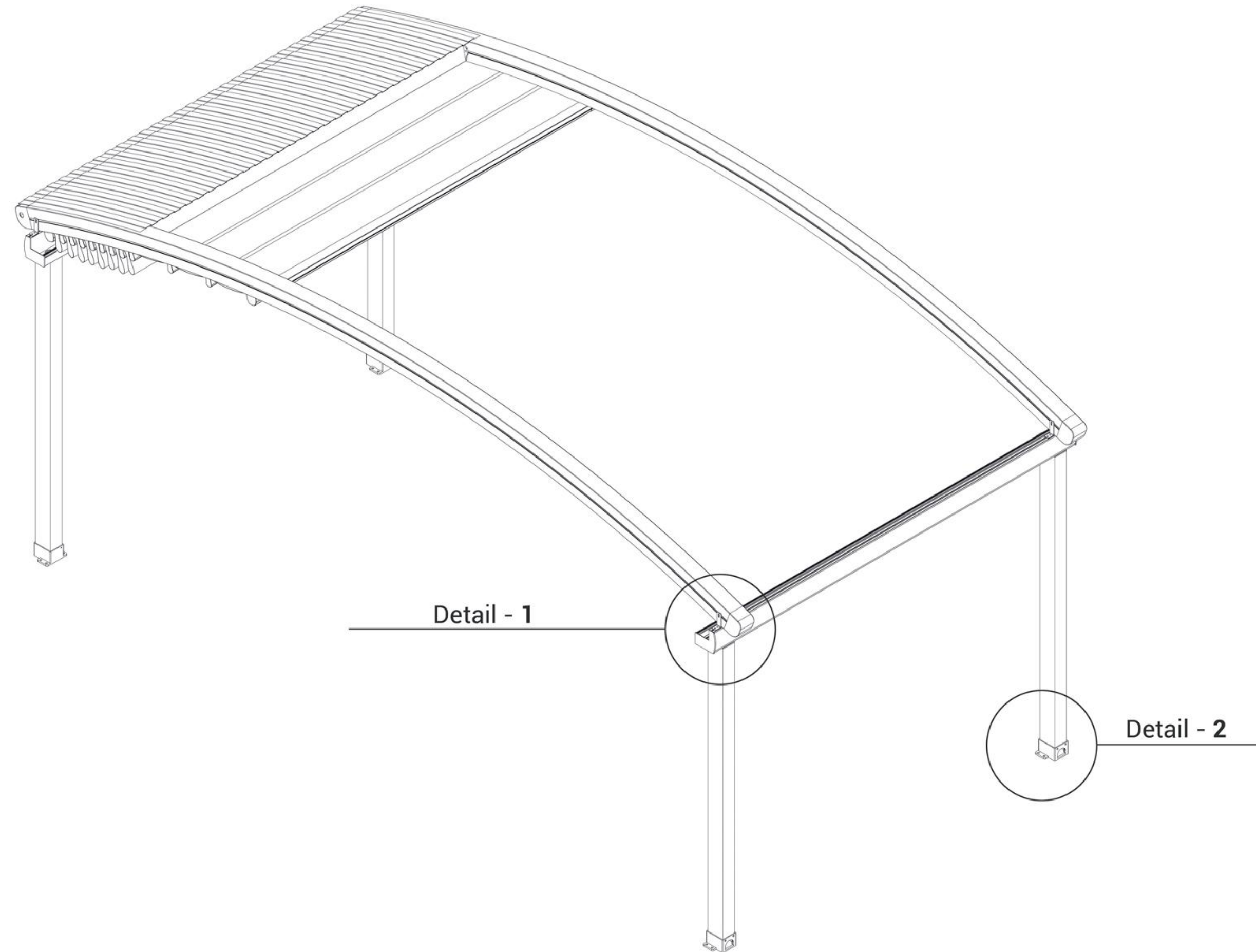

Detail - 1

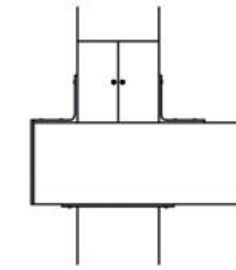

Type - A (Standard)

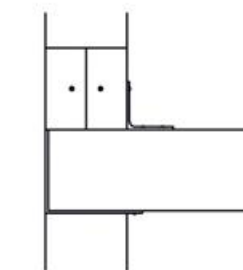

Type - B (Optional)

Detail - 2

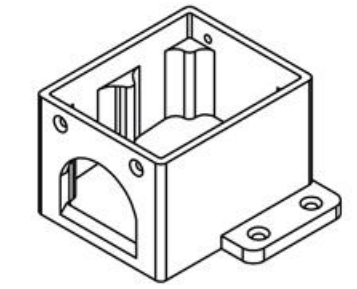

Type - A

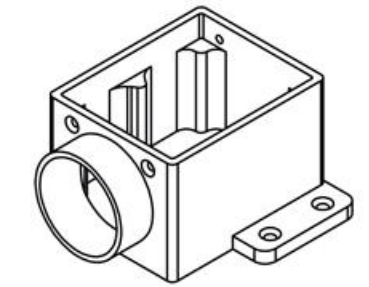

Type - B

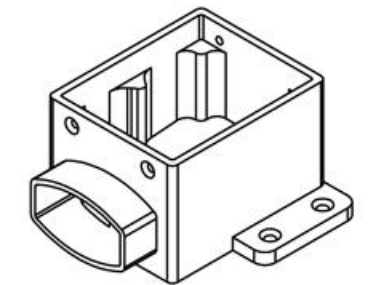

Type - C

OVERHANG SOLUTIONS

There are different types of awning options available to meet the needs of different locations and adapt to the location.

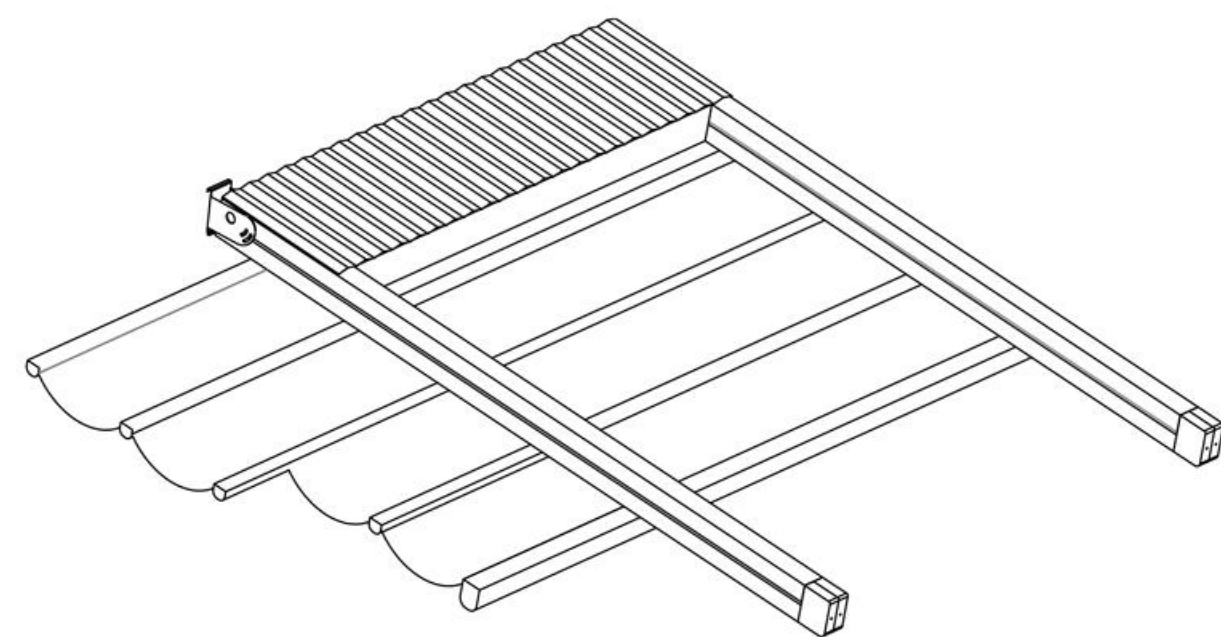

Type - B

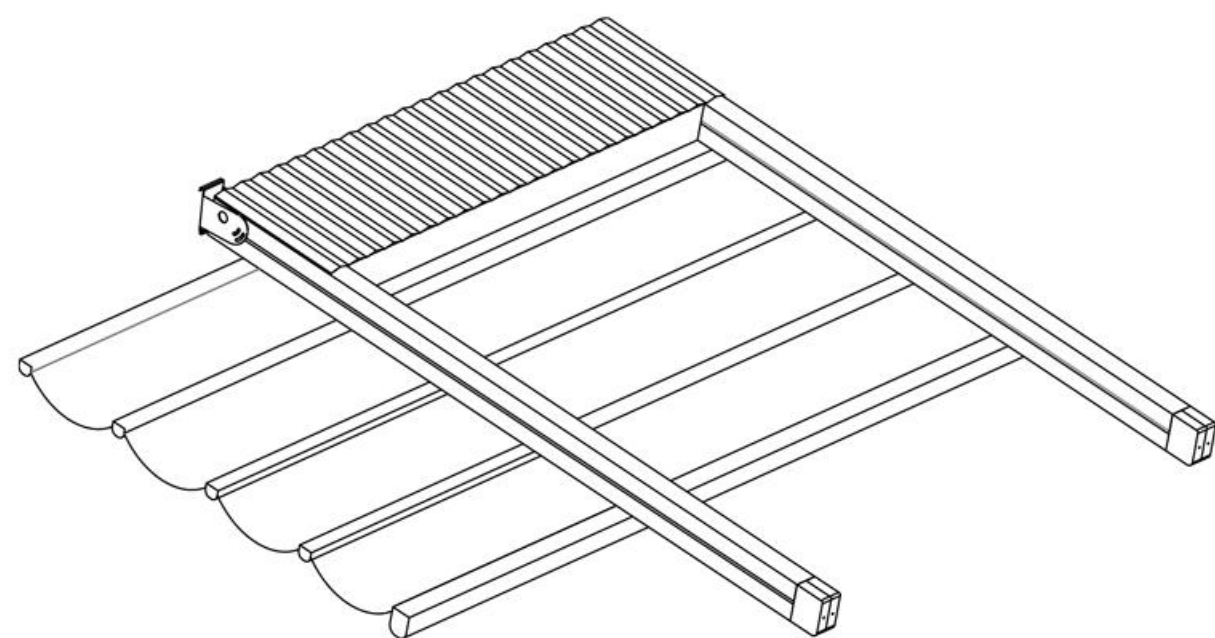

Type - A

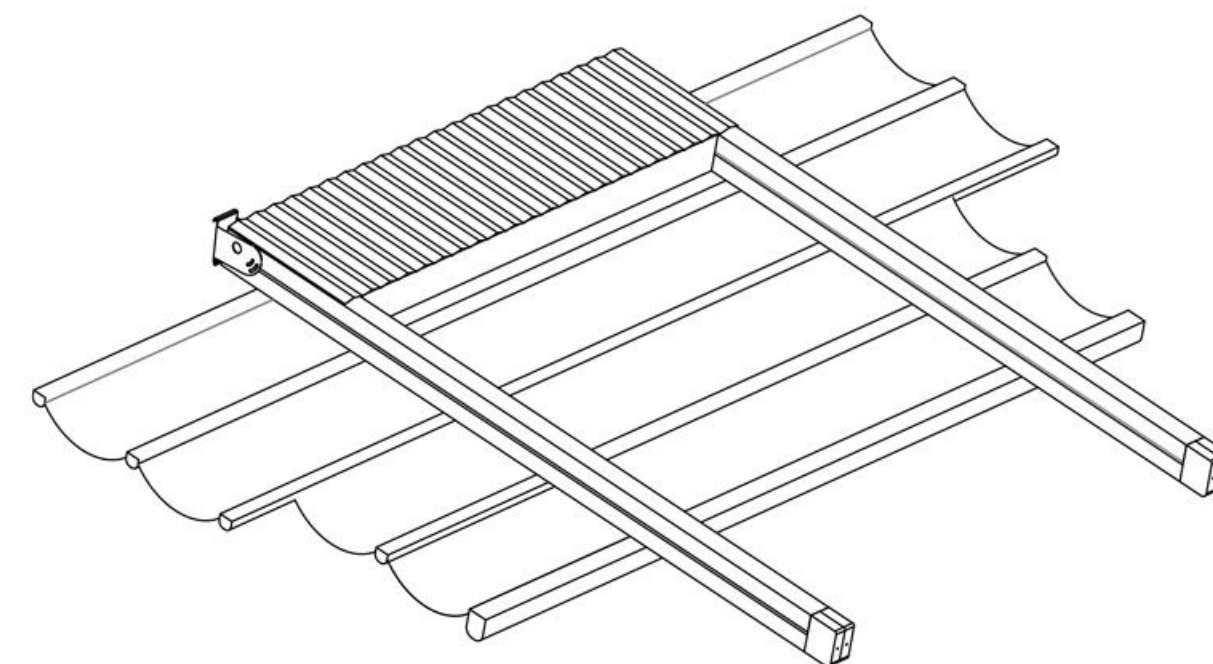

Type - E

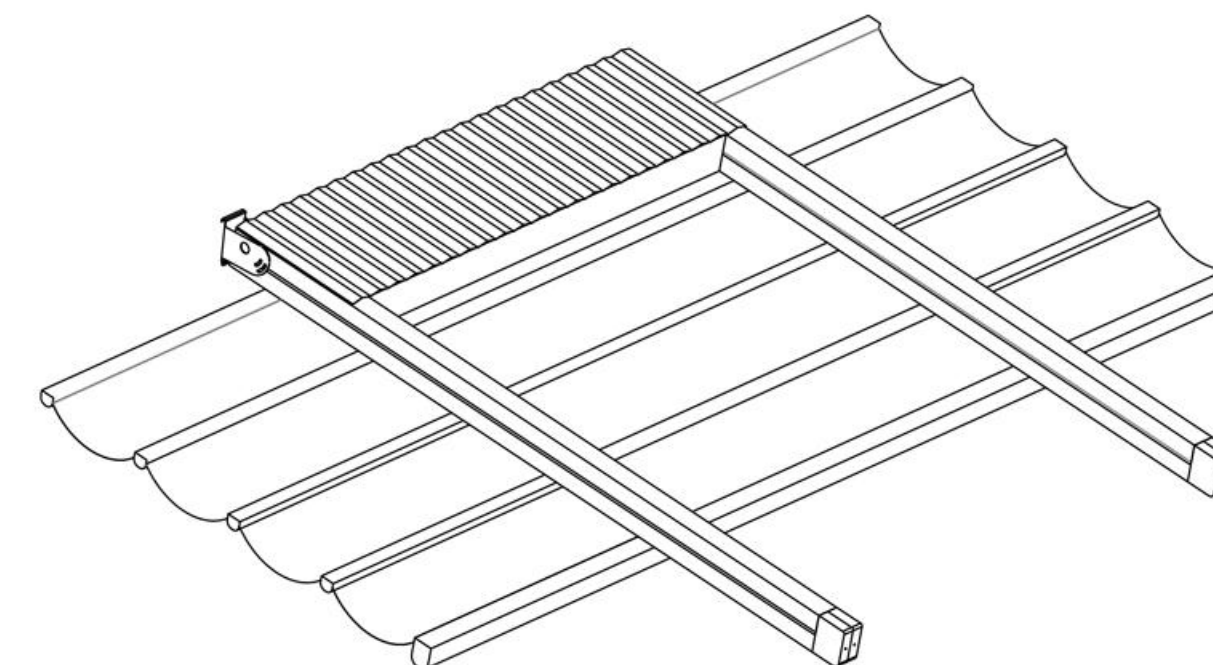

Type - D

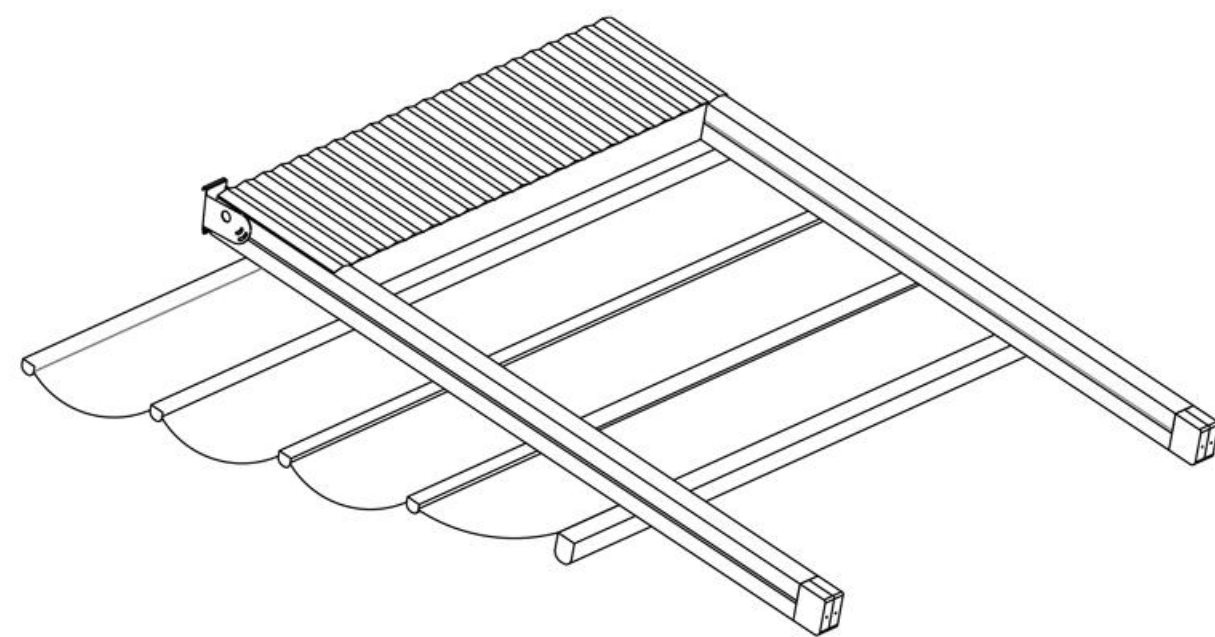

Type - C

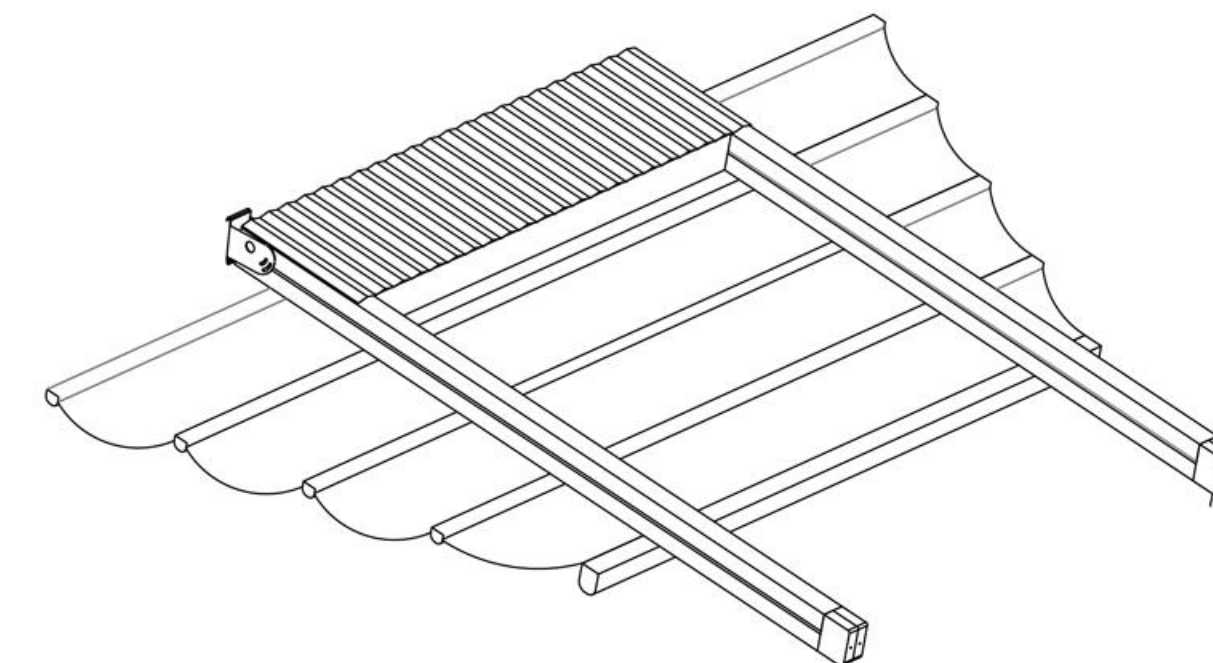

Type - F

INSTALLATION

Step - 1

The hanger is fixed to the carrier surface.

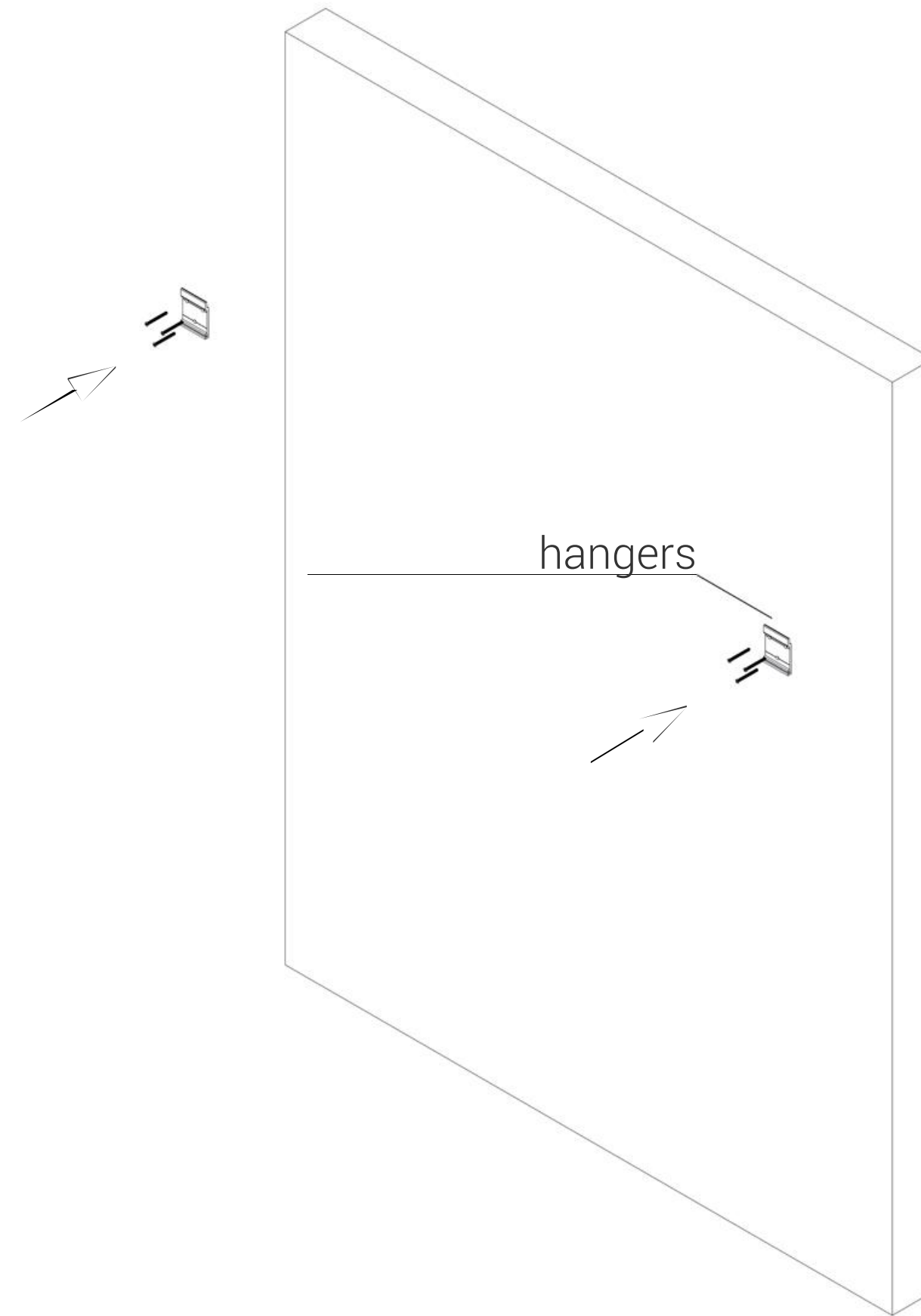

Step- 2

Stream profile is mounted on the posts that are fixed to the floor with the feet.

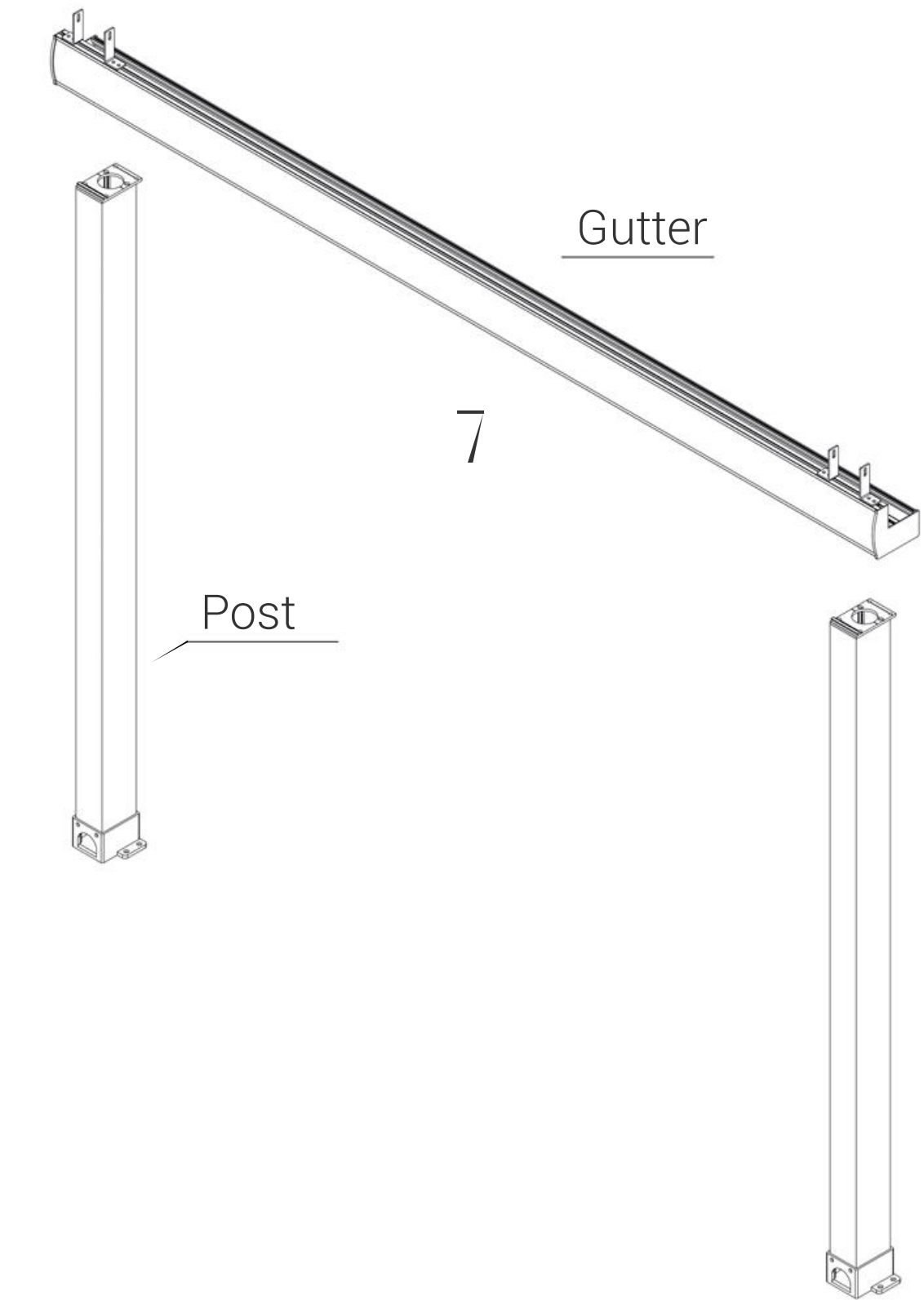

INSTALLATION

Step - 3

Rafters are mounted to the fixed stream profile and suspension apparatus with joint parts.

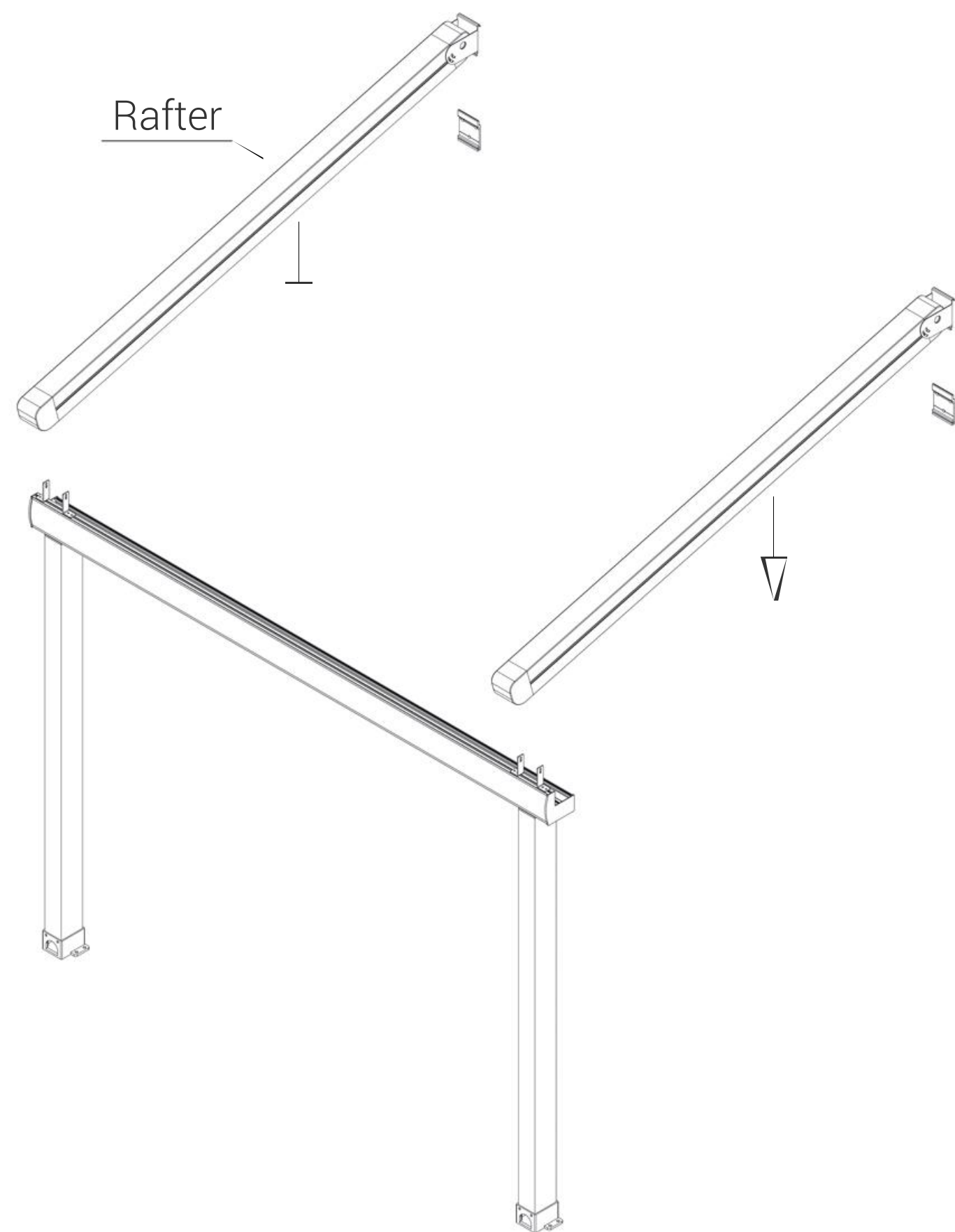

Step- 4

The motor box profile and the cover profile are fixed to the rafters.

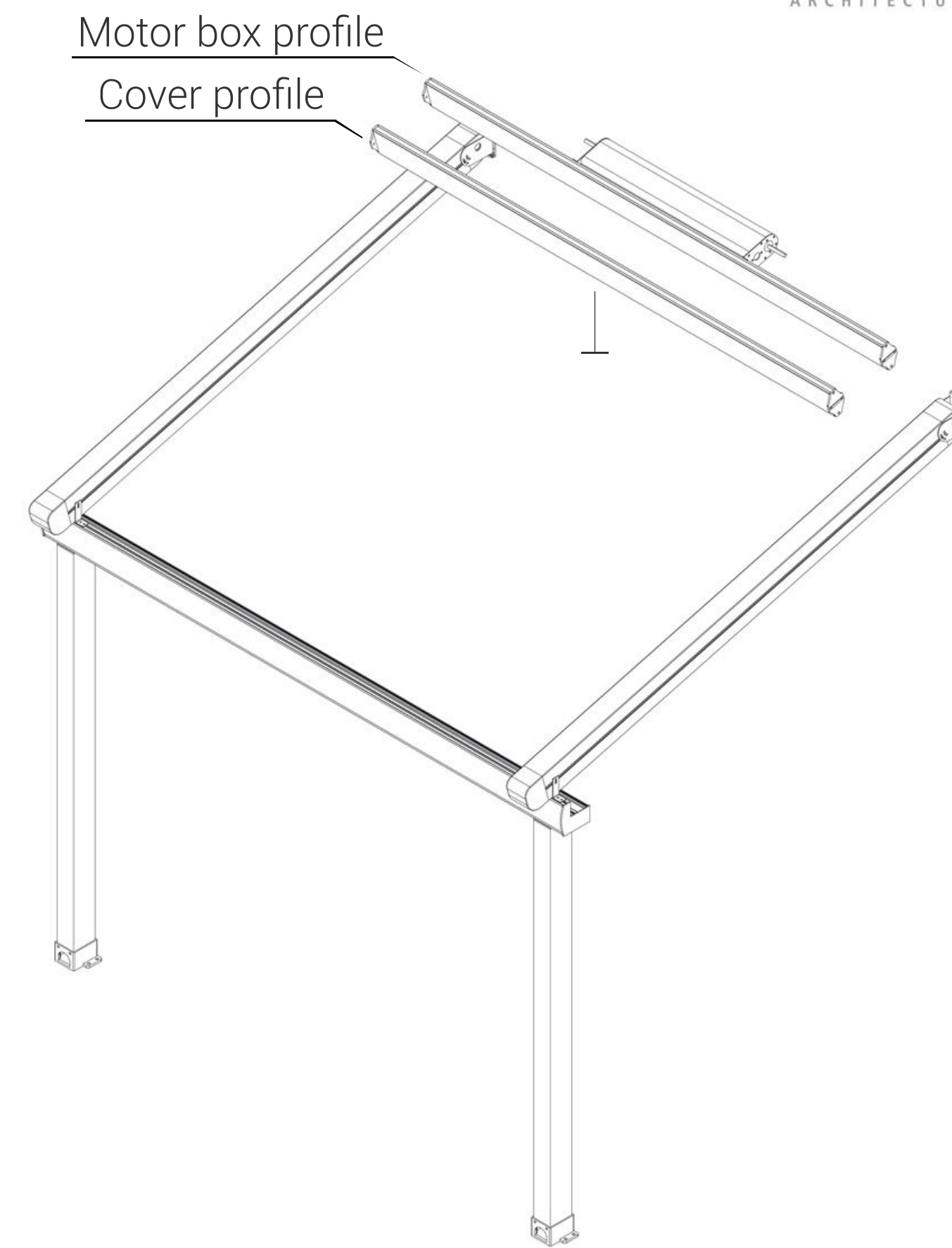

INSTALLATION

Step - 5

Transmission bar and square rod assembly that will transmit the motor movement is made from the sides.

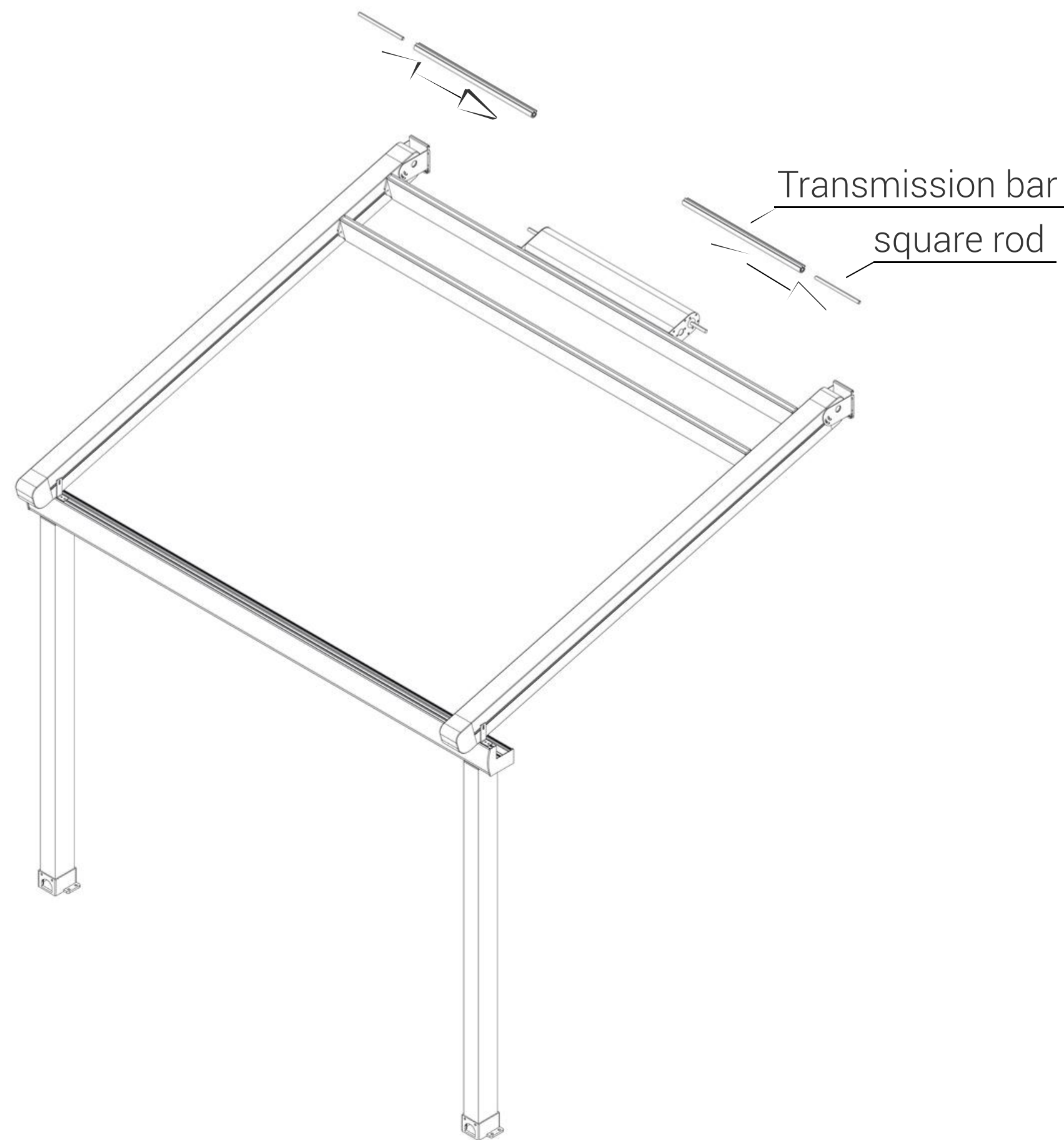

Step - 6

The fabric, the (illuminated) awning carrier and the puller profile are placed in the movement profile.

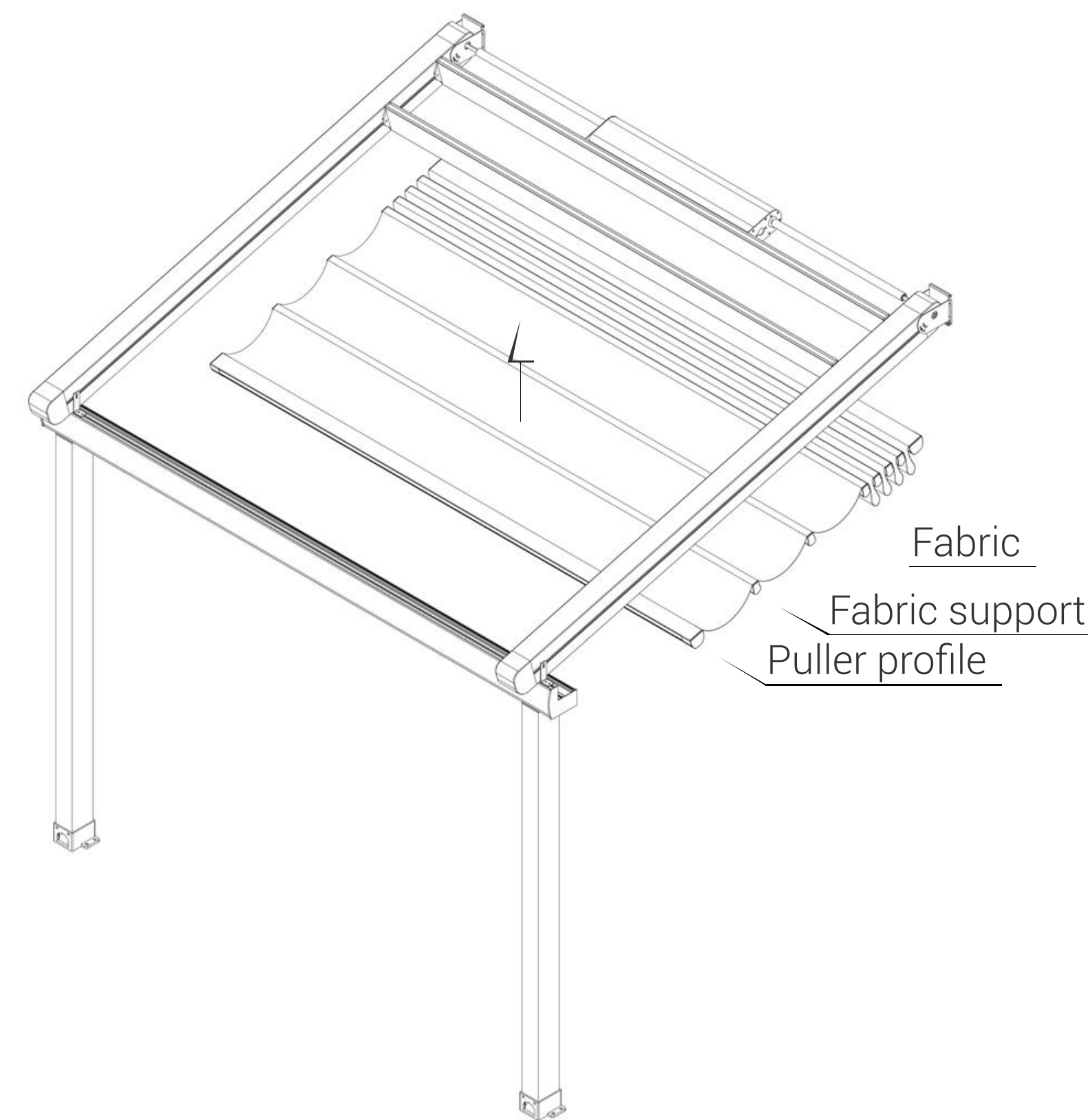

Step - 7

The clover profile position is adjusted again according to the retracted awning position.



Step - 8

The hood is fixed on the movement profile.

Thanks to its thin structure, it is light and while displaying an elegant stance, it protects the assembled awning mechanism and engine.

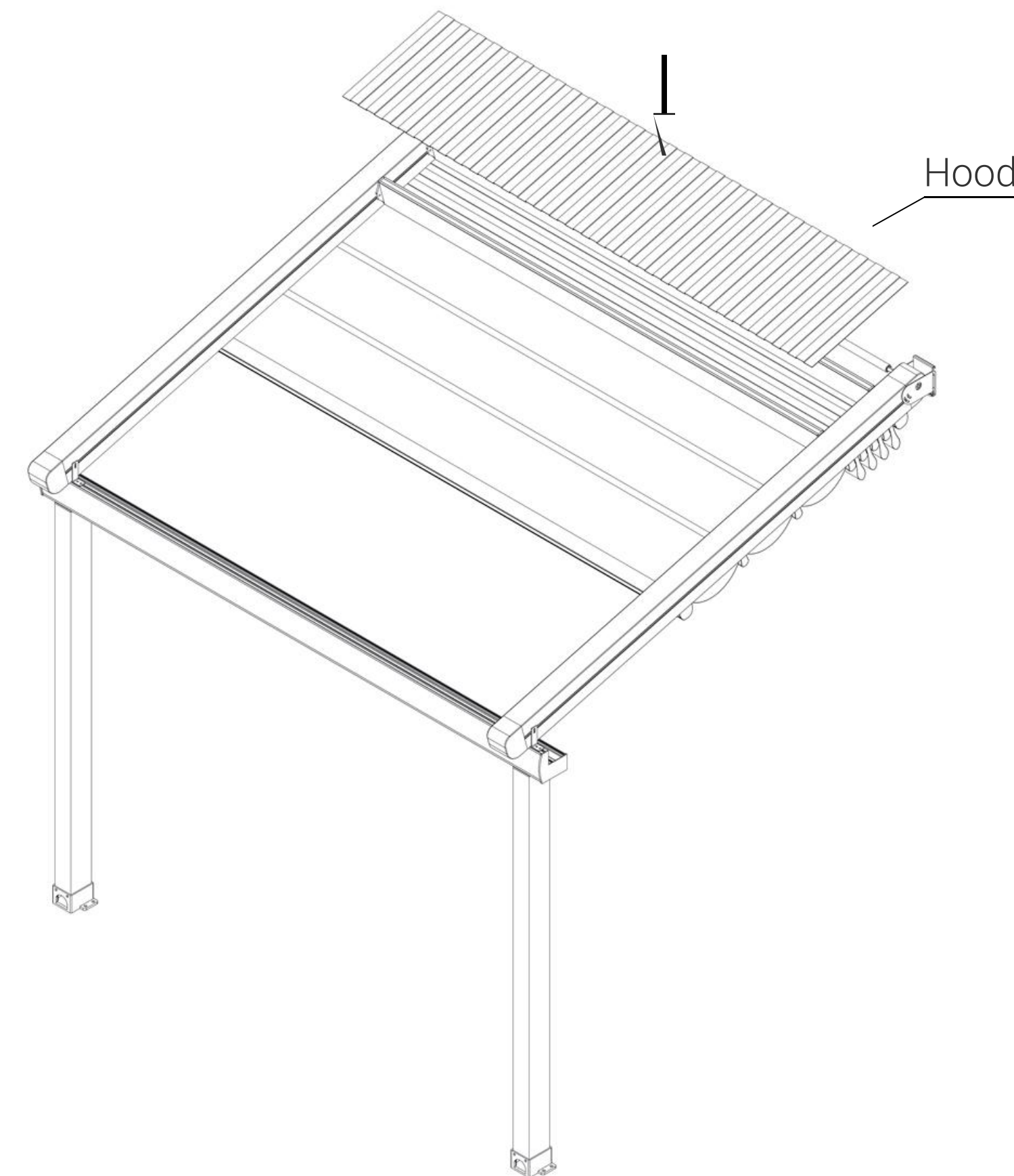

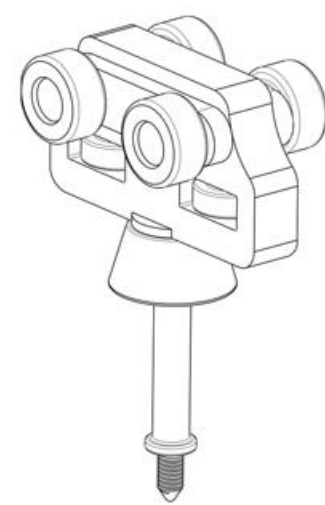

Six wheel slider
It provides smooth movement every time with four vertical and two horizontal wheels.

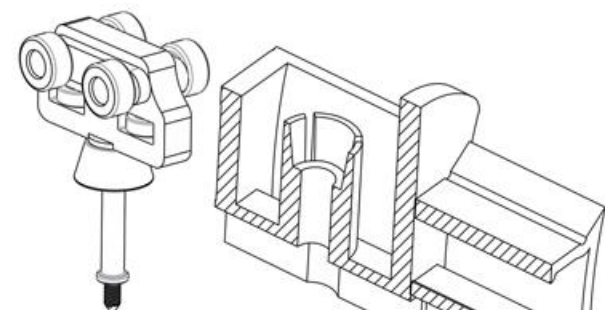

Slider easy clip installation
The awning fits into the carrier with a snap-on system and is easily fixed.

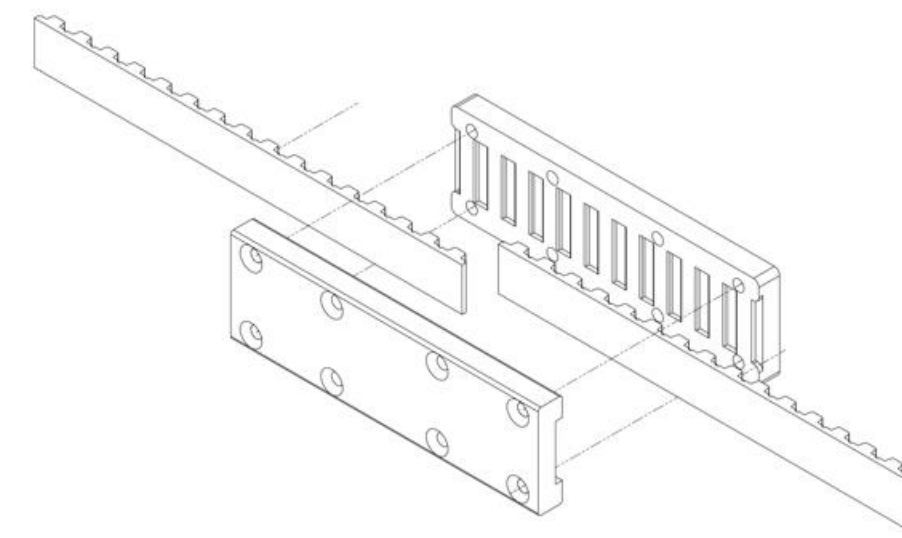

Trigger belt connection system
By attaching four teeth from both ends of the belt and connecting 8 imbus bolts, the belt stripping and breaking problem is eliminated.

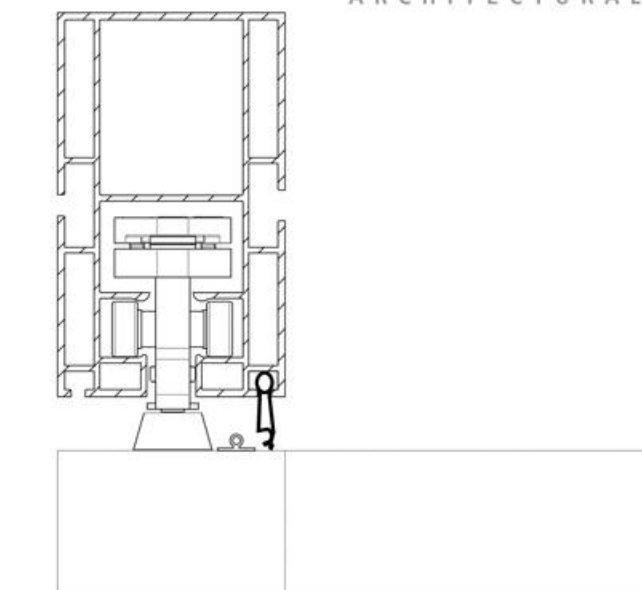

Rafter stormguard edge seal
The anti-drop edge prevents drops that may splash over the cable and water blowing in the wind.

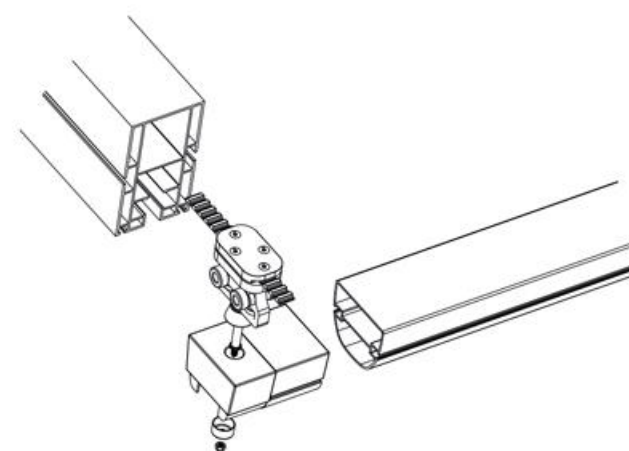

Slider and fabric profile assembly
The system is designed to save time and labor thanks to easy assembly.

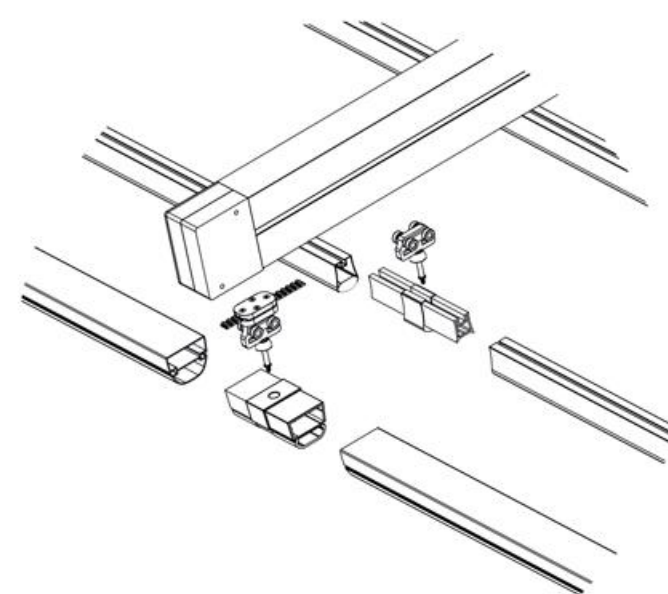

Easy clip intermediate joints (for 2 & 3 modules)
Easy-to-install spacers save time and require less labor.

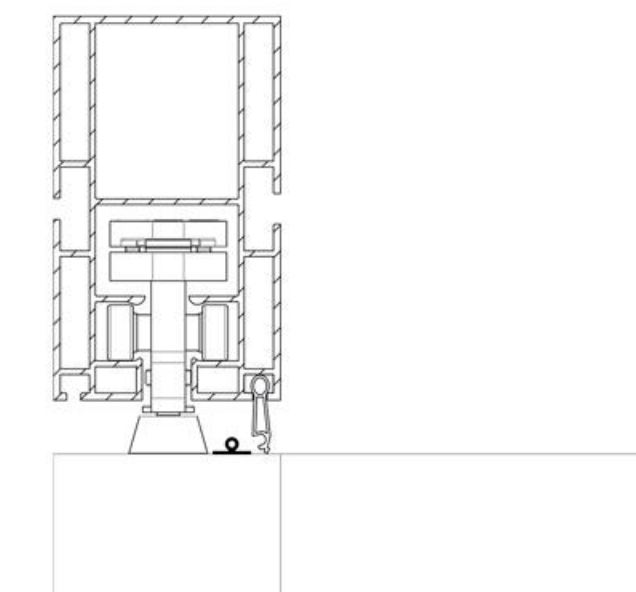

Fabric anti-drop edge cord
It prevents possible leaks by flowing to the sides of the awning.

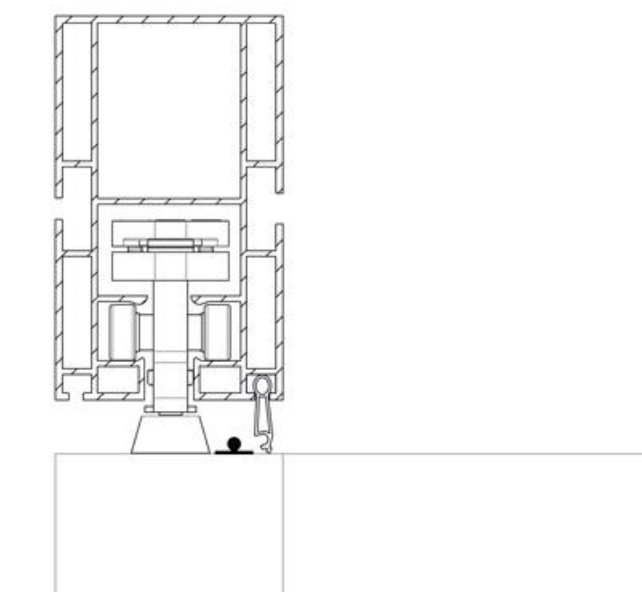

Fabric anti-drop edge cord with electrical cable
It prevents both leakage and provides energy to the awning led lights.

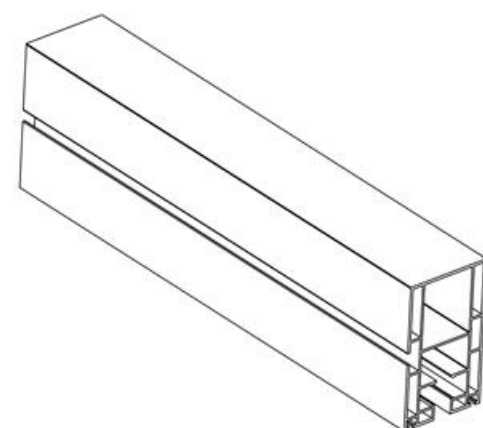

Rafter profile with waterguard side channels
Thanks to its special design, it does not get any water inside.

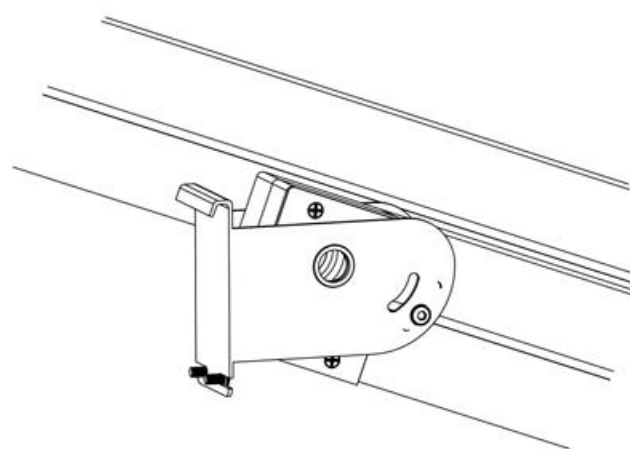

Double rafter wall bracket kit
Solution designed to fix two motion profiles.

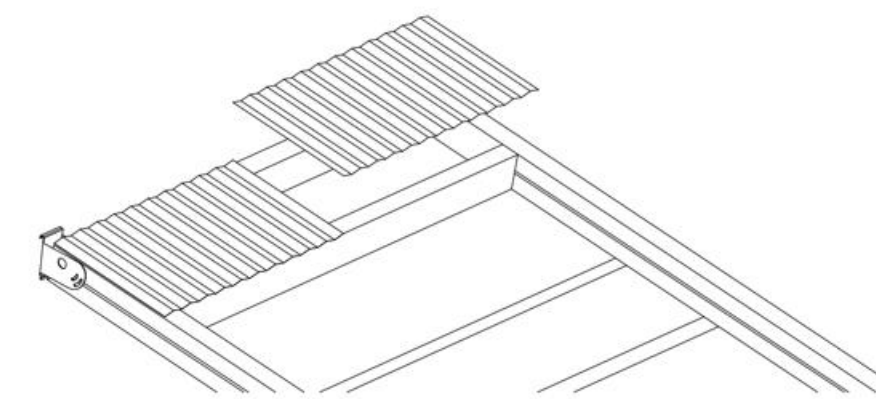

Hood profile sheets
The protection plate fixed on the movement profile has a thin structure. Elegant, light and sturdy, this piece protects the assembled awning mechanism and engine.

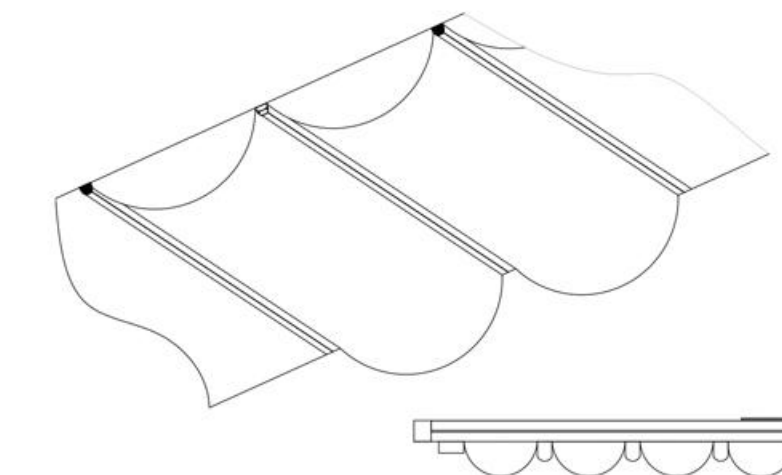

Decorative fabric under layer
This additional decorative fabric layer to be added under the standard protection layer provides an elegant and privileged look.

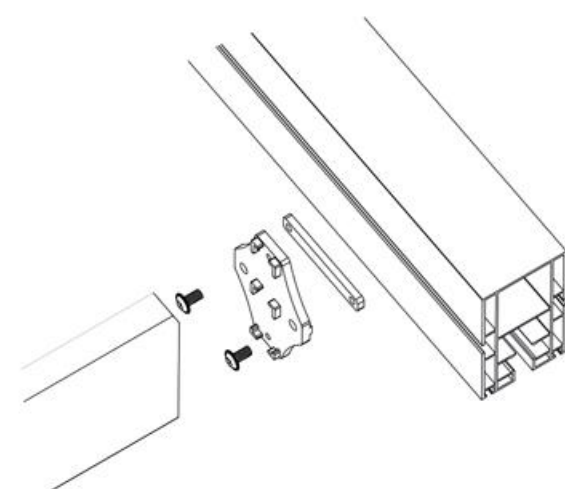

Motorbox support & hood support profile easy installation
The application of these profiles is very simple and can be easily adjusted during application.

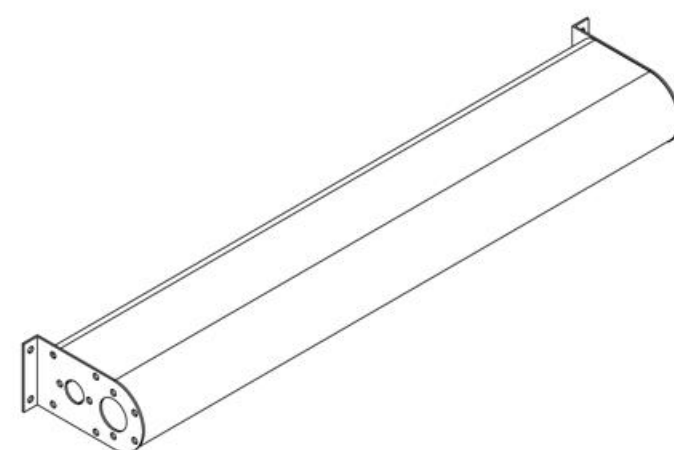

Compact 34 rpm direct drive motor box
The sunroof direct drive motor system is fast and efficient. It operates all motion systems at the same time. Thanks to its flat design, it has an additional area on the underside where the fabric can be collected.

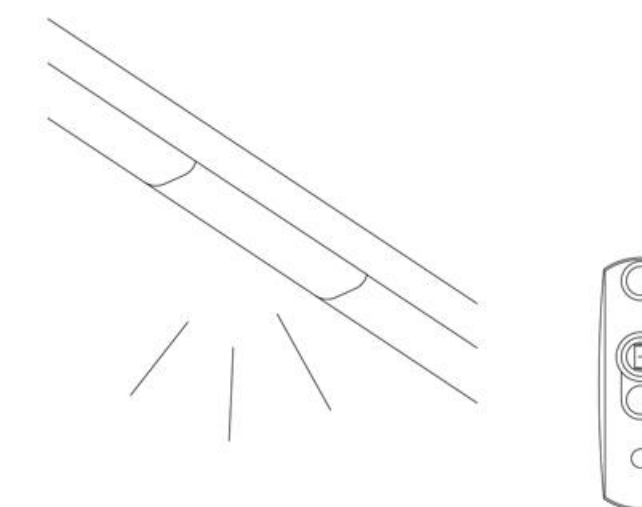

LED-TEC dimmer setup
It enables to increase or decrease the light intensity for the lighting products used in the awning system.

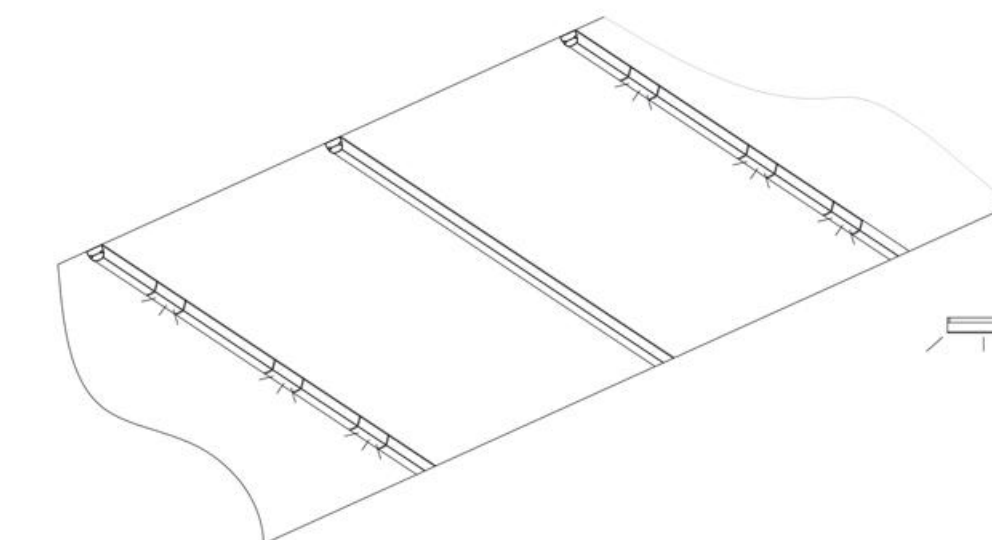

LED-TEC high powered lighting
Led lightings with different form and voltage options are selected with a power suitable for the environment and purpose in which they will be used, and ideal lighting is provided.

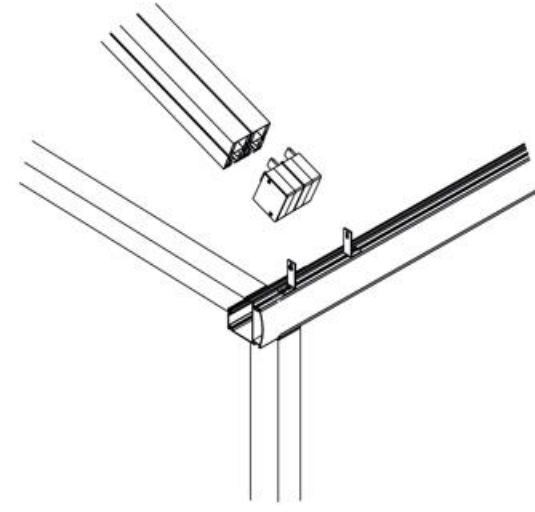

Storm channel for joining system

Storm channel is a patented solution for watertight coupling of two motion profiles.

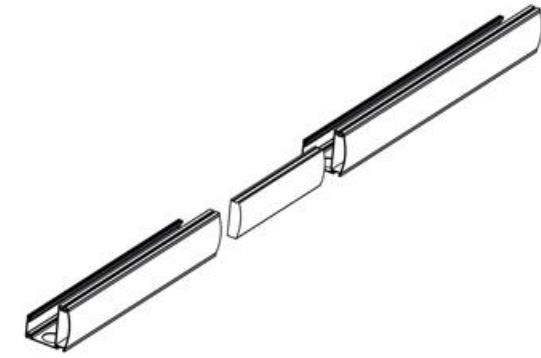

Gutter profile joining piece

A clever solution for combining stream profiles.

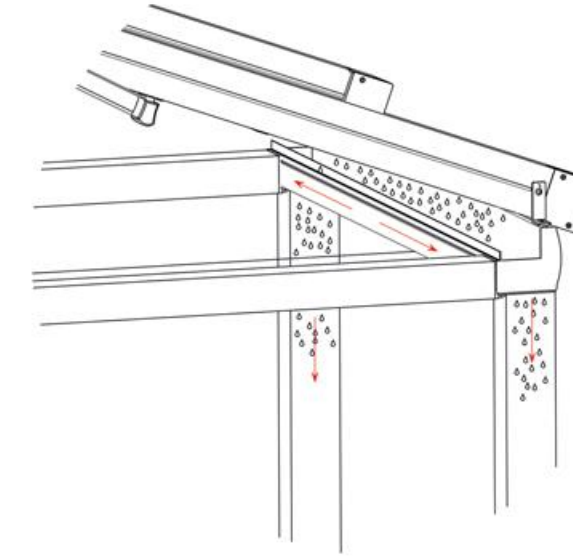

Integrated gutter & internal drainage system

Thanks to its integrated foot profile and stream profile, it provides invisible water drainage down to the floor.

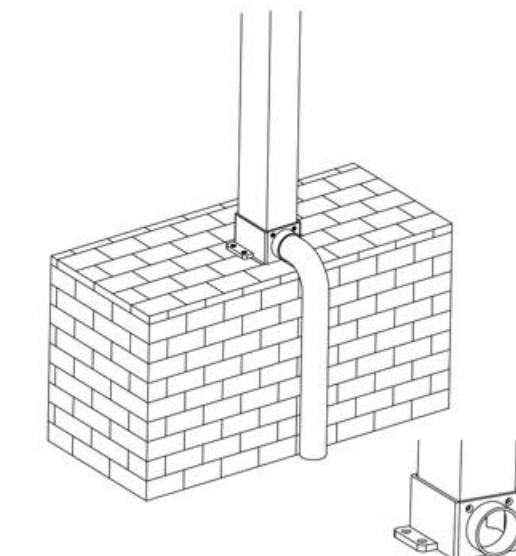

Base plate with external spout

Thanks to the additional drain tip, proper water routing is provided.

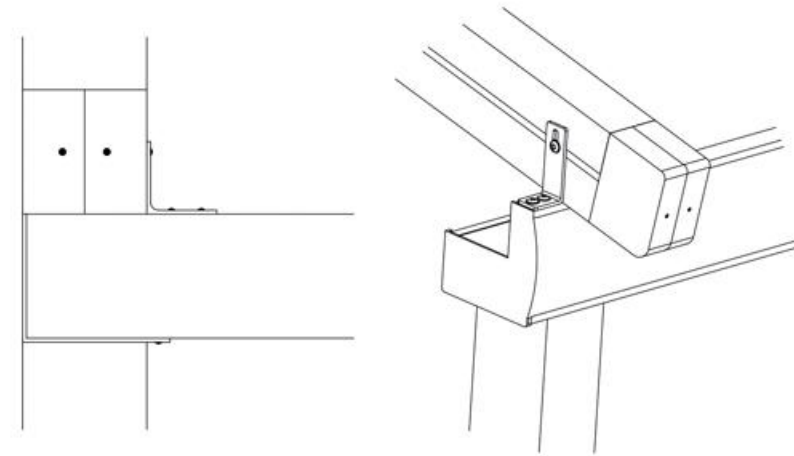

Gutter flush with rafter

This solution is applied if the system is flush with the wall or if eaves are not desired.

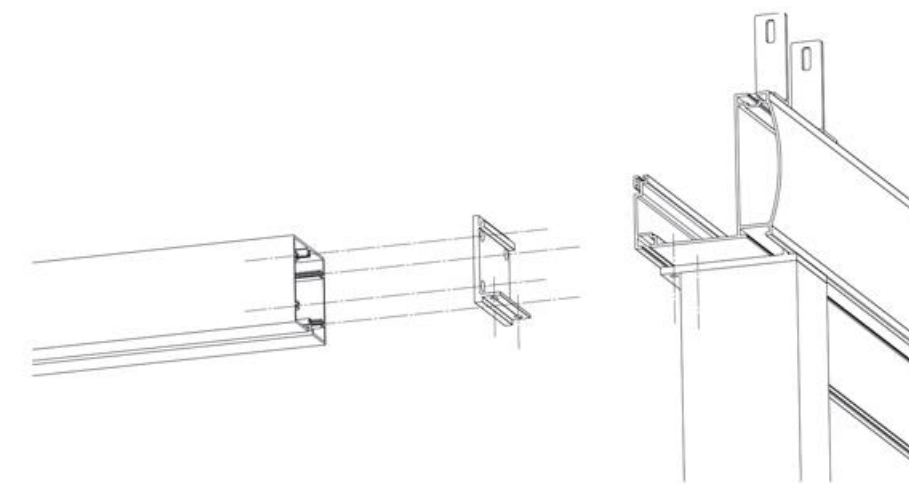

Side post

The specially designed spacer for the side profile to join with the stream profile provides easy and robust assembly.